

- Aluminum Diaphragm
- NBR Rubber Surround
- Neodymium Motor
- Copper Cap
- Enhanced Voice Coil Cooling

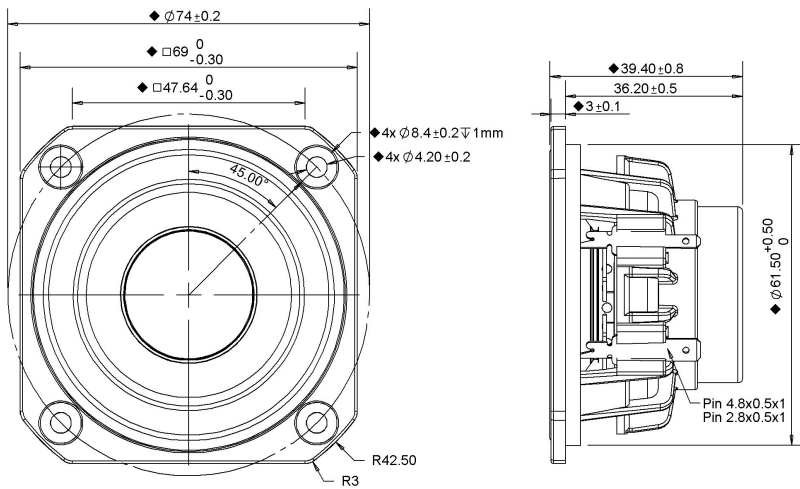

**SPECIFICATIONS**

Transducer Size	2.5	in
Impedance	4	$\Omega$
Frequency Range <sup>1</sup>	80 - 15000	Hz
Sensitivity <sup>2</sup> (2.83V   1W @ 1m)	84.9   81.9	dB
Power Rating (IEC 268-5)	30	W
Voice Coil Size	25.7	mm
Air Gap   Winding Height	$H_{ag}   H_{vc}$	3   6.3 mm
Net Weight	0.14	kg

**PARAMETERS <sup>3</sup>**

Eff. Piston Area	$S_d$	21.2	cm <sup>2</sup>
DC Resistance	$R_e$	3.6	$\Omega$
Minimum Impedance	$Z_{min}$	3.8	$\Omega$
Inductance	$L_e$	0.062	mH
Resonance Frequency <sup>4</sup>	$F_s$	120	Hz
Mechanical Q Factor	$Q_{ms}$	4	-
Electrical Q Factor	$Q_{es}$	0.857	-
Total Q Factor	$Q_{ts}$	0.71	-
Moving Mass	$M_{ms}$	2.29	g
Compliance	$C_{ms}$	740	$\mu m/N$
Equivalent Volume	$V_{as}$	0.475	L
Motor Force Factor	Bl	2.72	Tm
Motor Efficiency	$\beta$	2.05	(Bl) <sup>2</sup> / $R_e$
Linear Excursion <sup>5</sup>	$X_{max}$	2.65	mm
Max Mechanical Excursion <sup>6</sup>	$X_{mech}$	-	mm

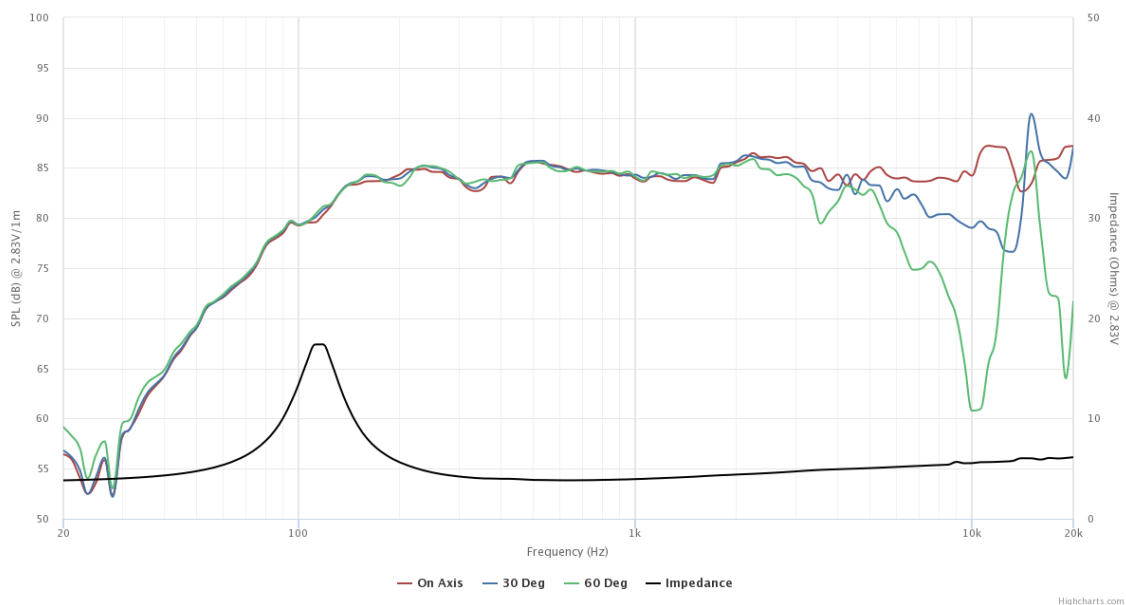

Details on this spec sheet are for reference only and should not be used for setting production limits. Specifications and product cosmetics are subject to change without notice. Peerless is a registered trademark of Tympany Enterprises. All measurements conducted in test lab at 25°C ±10°C, 50%RH ±10%. <sup>1</sup> Specified by Engineering as linear working range of transducer. <sup>2</sup> Measured at 2.83V at 1m and normalized to 1W with respect to nominal impedance. <sup>3</sup> Measured in Free Air without preconditioning, therefore subject to some deviation. <sup>4</sup> Impedance and  $F_s$  value measured under different conditions. <sup>5</sup> Equal/Overhung:  $(H_{vc} - H_{ag})/2 + H_{ag}/3$ . Underhung:  $(H_{ag} - H_{vc})/2 + H_{vc}/3$ . <sup>6</sup> Mechanically limited excursion (e.g. bottoming, spider crash).